

## Introduction of APsystems YC600 Anti-reflux System solutions

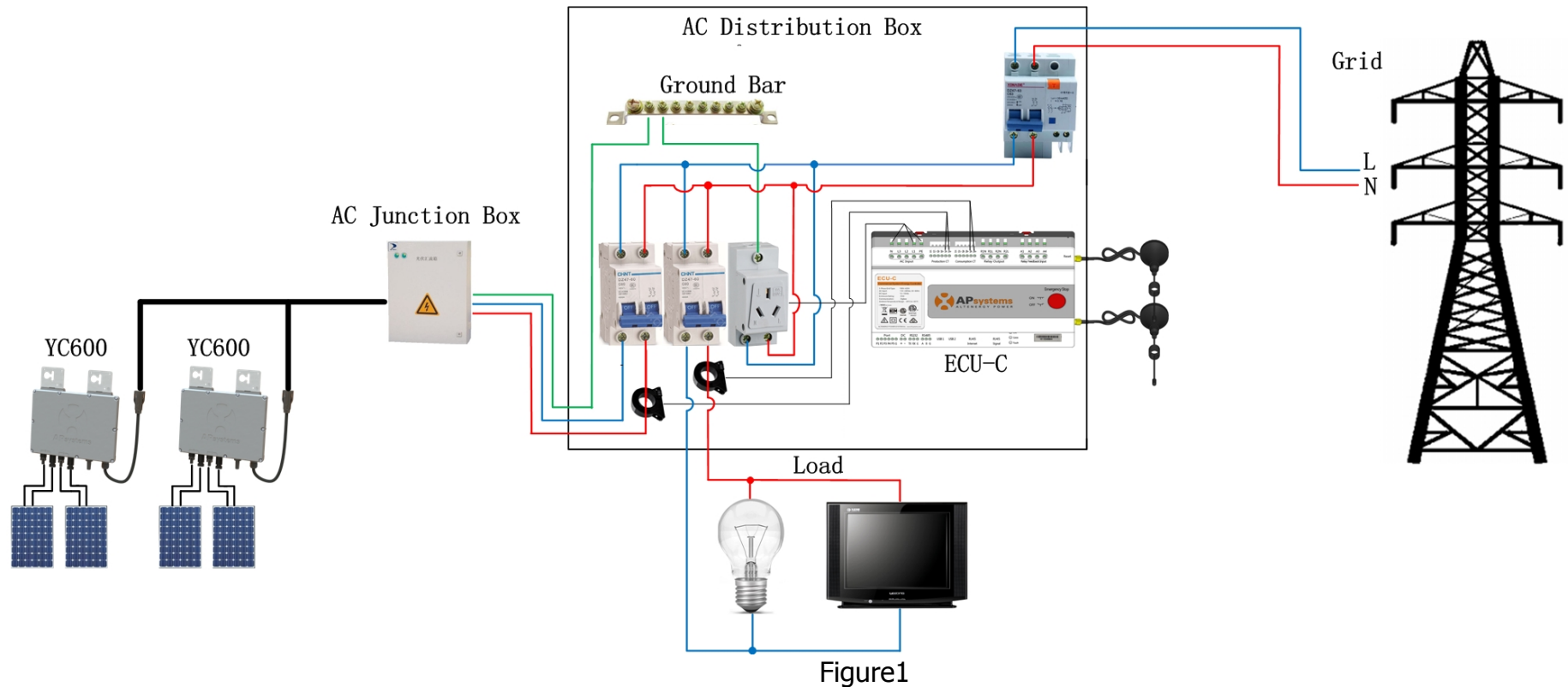

APsystems YC600 Anti-reflux System solutions schematic diagram, please refer to figure 1. To the power generation side and consumption side of PV power generation system, each side has a current transformer. ECU-C could measure and compare the power generation and power consumption by these transformers. When the power generation is more than power consumption, then the electric current will flow back into the grid, that's so called reflux. To avoid the reflux, ECU-C will shut all the inverters down at the moment that the reflux occurs. According to the power calculation, under the condition of no reflux, ECU-C will allow to switch on inverters as many as possible to guarantee the maximum power generation.

**APsystems**

Suite 502, 8 Help Street, Chatswood NSW 2067 Australia  
61 (0)2 8034 6587 | APsystems.com

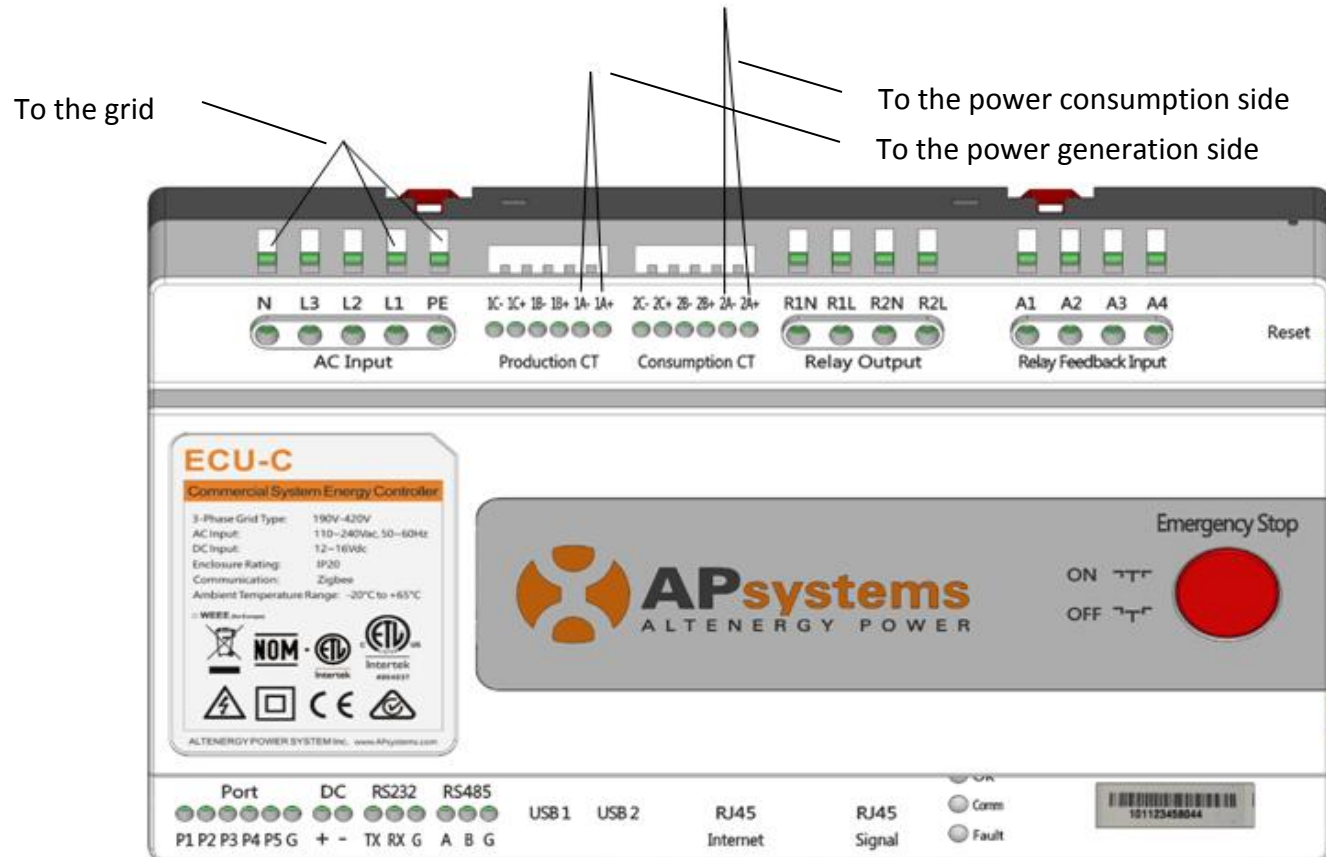

Figure2

ECU-C wiring diagram, please refer to figure2. The AC input side L1, N, PE should be accessed to the grid. At the Production CT, the current transformer between 1A+ and 1A- should be accessed to the power generation side of PV system. At the Consumption CT, the current transformer between 2A+ and 2A- should be accessed to the power consumption side of PV system. ECU-C has no requirement for the wiring polarity and coil embeded direction of current transformer.